





SPECIFICATIONS

CUSTOMER	
ITEM	LINE FILTER
MODEL	20mH (NSH-200)
TYPE	UU1620 (H)

DESIGN	CHECK	APPROVAL
		
2015.09.03	2015.09.03	2015.09.03
A TERM OF VALIDITY		YEAR

REQUEST CUSTOMER	 SAMHYUNG ELECTRONICS CO., LTD.		
ADDRESS	Na-3506, Chungang Circulation Complex, 1258 Kurobon-dong, Kuro-Ku, Seoul, Korea, 152-721		
TEL	02-2689-9418	FAX	02-2689-8628
HOMEPAGE	http://www.nsn.co.kr		



MODEL

20mH(NSH-200)

Revision 0

REVISION RECORD

REV NO.	DATE	PAGE	REVISION CONTENTS	REVISION REASON
0	15.09.03		-. 초기작성	
1				
2				
3				
4				
5				
6				
7				
8				
9				
10				
11				
12				
13				
14				
15				
16				
17				
18				



MODEL

20mH (NSH-200)

Revision 0

1. APPEARANCE & DIMENSION

<TOP VIEW>

Marking : NSH-200

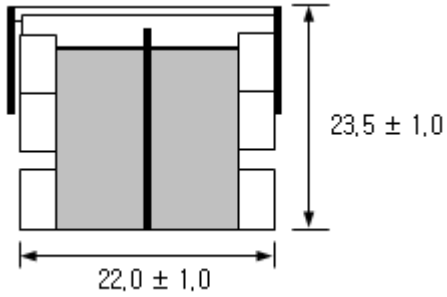

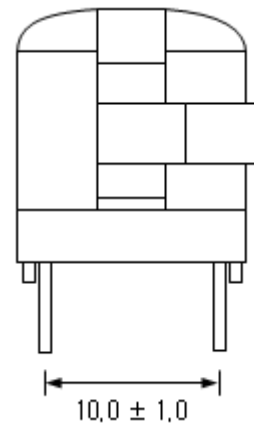
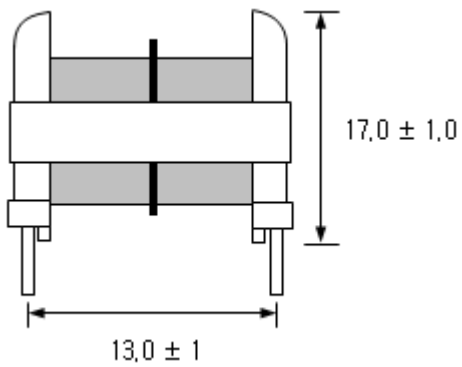

<FRONT VIEW>

<SIDE VIEW>

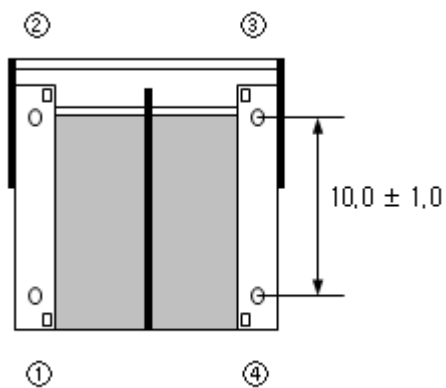

<BOTTOM VIEW>



	MODEL	20mH (NSH-200)	Revision 0
---	-------	----------------	------------

2. WINDING CONNECTION SCHEMATIC (BOTTOM VIEW)

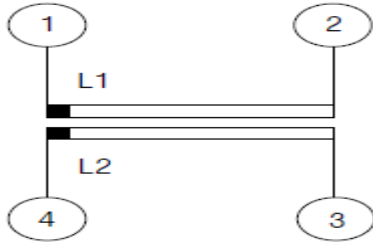

WINDING	BOTTOM VIEW	C.C.W
N.C PIN		
REMOVE PIN		
TUBE		

3. WINDING SPECIFICATION

NO	TERMINAL		WIRE	TURNS	L (H)	WINDING METHOD	INSULATION		BARRIER	
	S	F					MATERIAL (P.S TAPE),T/W	Ts	PIN	TOP
L1	1	2	2UEW Φ0.4	90	(1,4-2,3) PIN 20mH MIN	SOLENOID	-	-	-	-
L2	4	3	2UEW Φ0.4	90		SOLENOID	-	-	-	--

4. ELECTRICAL CHARACTERISTICS

NO	CLOSURE	TERMINAL NO.	SPECIFICATION	CONDITION
1	INDUCTANCE	1 – 2 4 – 3	20mH MIN	LCR METER LCR-745 (1KHZ. 1V)
2	DC RESISTANCE	1 – 2 4 – 3	Ω MAX	
3	INSULATION RESISTANCE	COIL - CORE	100 Mohm MIN at DC 500V	MEGOHM METER (SM-5E)
4	WITHSTANDING VOLTAGE	COIL – CORE	AC 1.5KV RMS 1MIN	KIKUSUI : TOS-5050 Cut off CURRENT 10mA

5. CONSTRUCTION

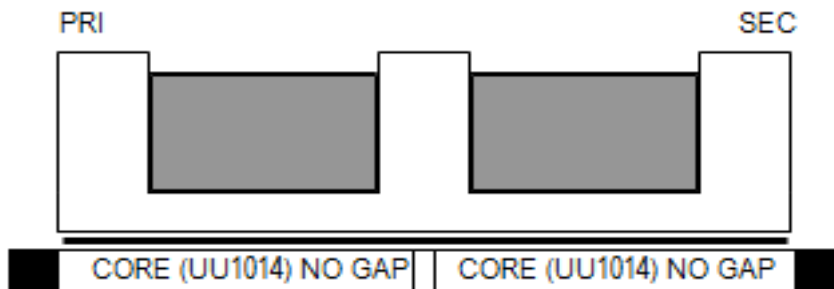

	MODEL	20mH (NSH-200)	Revision 0
---	-------	----------------	------------

6. MATERIAL LIST

NO	COMPONENT	NAME OF MATERIAL	MANUFACTURER OF MATERIAL	UL No.
1	CORE	R7K (UU 1620) R10K (UU 1620)	SHANGHAI JISHUN MAGNETIC MATERIAL CO.,LTD.	
2	BOBBIN	PHENOL RESIN 94V-0 [UU1620 4P H-TYPE]	MOMENTIVE SPECIALTY CHEMICALS GMBH CHANG CHUN PLASTICS CO.,LTD.	E61040 E59481
3	WIRE	POLYURETHANE 2UEW 0.4Ø	SHANDONG PENGTAI STOCK CO.,LTD. YOUNG HWA PRODUCTION CO.,LTD.	E166187 E141925
4	SPRING HOLDER	STAINLESS STEEL SUS31	DAEHYUN INDUSTRIAL JINWON BOBBIN.	
5	VARNISH	EVD-3200 / EH-3200 T-4260	E-WEON CHEMTECH CO.,LTD. SUZHOU TAIHU ELECTRIC ADVANCED MATERIAL CO LTD	E101220 E228349
6	FLUX	LF-715K	DUIYUANINDUSTRY SCIENCE&TECHNOLOGY(HUIZHOU)CO.,LTD.	
7	SOLDER	SN99.5% , CU0.5%	HEESUNG MATERIAL CO.,LTD. ALPHA OMEGA METAL	